

# Waterway MasterPump

CONDENSATE REMOVAL SYSTEM



## INSTALLATION OPERATION AND MAINTENANCE INSTRUCTIONS

For Installation and Service Engineers.

### IMPORTANT:

- The installation of this product is to be carried out by Competent Engineers.
- **READ THIS BOOKLET** (before installation of this Product).

### Retention of this Installation Book

This Installation Book must be kept for reference as it contains important details on the safe and proper installation and maintenance of this product.

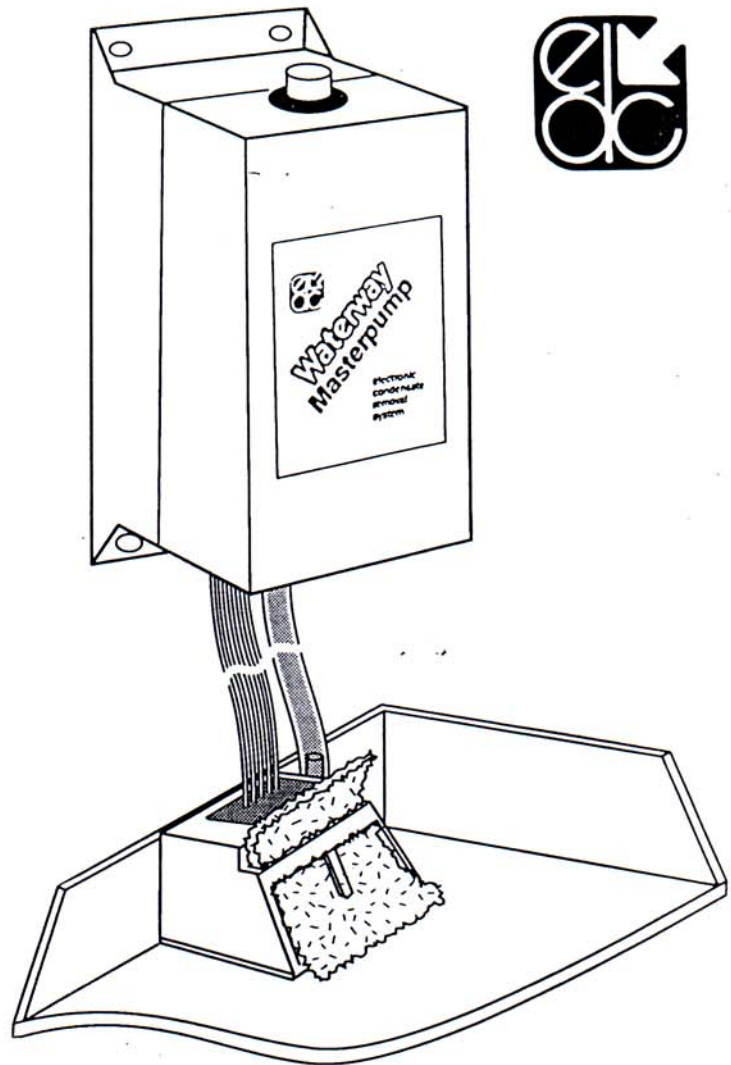

### DESCRIPTION

The "WaterWay" MasterPump is a universal condensate removal system, designed to meet the requirements of most Air Conditioners for Condensate Removal. It comprises of a pump and control module with a remote sensor which can be positioned in a collection tray or suitable sump. The pump is capable of removing up to 60 litres of condensate per hour but has the optional "Whisper" mode for lower capacity systems or where noise is a consideration. The water detection is by safe low voltage electronic probes, featuring a high level alarm facility which operates a volt free change over relay, which can be wired into A/C systems to give an alarm and/or shut down of the A/C unit in the case of high condensate level. The sensor is supplied complete with a filter and securing clip for ease of installation and maintenance.

### TECHNICAL DATA

#### ELECTRICAL SPECIFICATION

Volts: 230V  
 Frequency: 50-60 Hz  
 Power: 40W max.  
 Fuse required: 3 amp.  
 Alarm Relay Rating: 13 amp 250V AC  
 Terminals: Rising clamp 3.5mm<sup>2</sup> max.  
 Protection: IP 10



**NOTE:** CE marking certifies that this product complies with the requirements laid down in the EEC directives:-  
 EMC 89/336/EEC  
 LVD 73/23/EEC

#### HYDRAULIC SPECIFICATION

Water Temperature: 40°C (max.)  
 Head (max) Total: 9M  
 Suction Lift: 3M  
 Length (max): 30M  
 Capacity (min) Ltr/Hr: see graph

#### Level sensing

Pump switch (on): (a) 10mm  
 Pump switch (off): (b) 6mm  
 Alarm Relay: (c) 14mm  
 Hose connection Ømm: 6mm or 1/4" (wall 1.6mm or 1/16")  
 Weight (packed) 1Kg

OUTLET FLOW

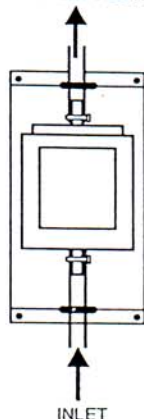

Connections:  
 Ø 6mm  
 Ø 1/4 in.

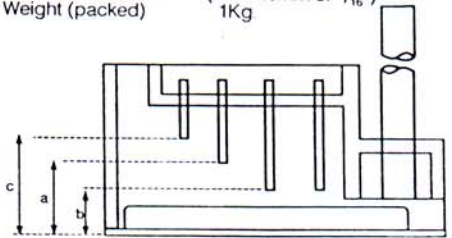

### DIMENSIONAL SPECIFICATION

Pump and Control Module

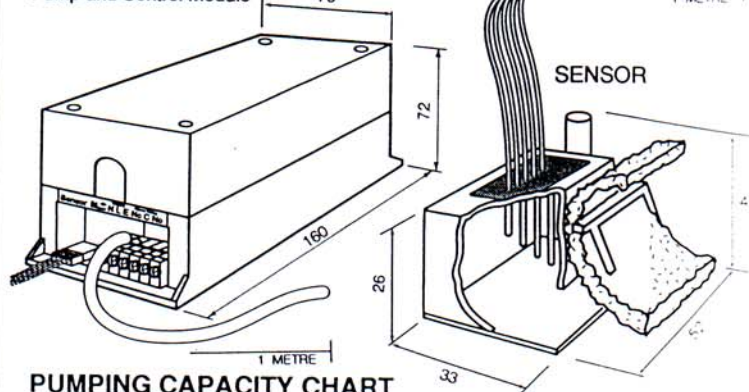

### PUMPING CAPACITY CHART

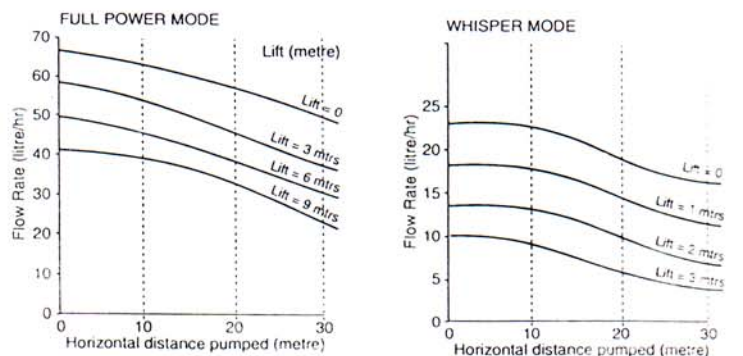

**SAFETY**

Always disconnect all power supplies before commencing installation or maintenance on this equipment. The MasterPump must be installed within the host equipment and/or its associate parts which must ultimately provide the necessary electrical protection. The power cable attached to the MasterPump must not enter or exit the user space without appropriate retention. The MasterPump must be fused at 3 amps at the source of supply to the pump.

The installation must comply with All National and Local Regulations for Electrical Safety. The MasterPump must be positioned in a dry area of the equipment where splashing or drips cannot come in contact with the electrical parts.

**IMPORTANT**

The wires in the mains lead fitted to this product are coloured in accordance with the following code:

BLUE = NEUTRAL  
BROWN = LIVE

If the colours of the wires in the mains lead of the Air Conditioner or Fan Coil (designated "Host Equipment") are different from the colours above, proceed as follows:

The wire which is coloured blue must be connected to the terminal which is marked with the letter N or coloured black.

The wire which is coloured brown must be connected to the terminal which is marked with the letter L or coloured red, which must be fused at 3 amps.

**INSTALLATION INSTRUCTIONS**  
**COMPONENTS SUPPLIED**

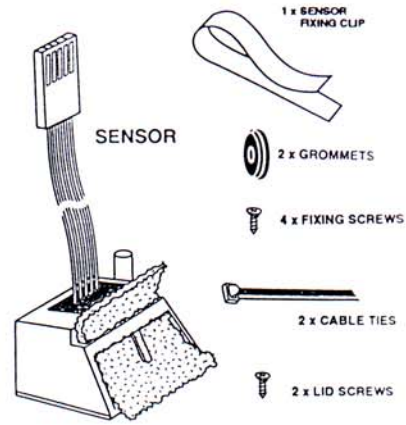
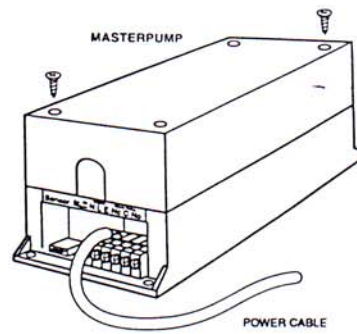

**INSTALLATION-AT-A-GLANCE**

**Warning: Before accessing electrical terminals, Isolate ALL supplies.**

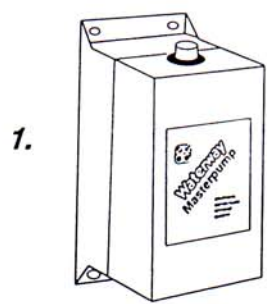

1.

1] Use 3.5mm self-taping screws down through the holes  
**Fixing centres 151 x 63mm**  
**Note:** Pump Module must be fitted inside an enclosure that prevents contact with electrical wiring or terminals.

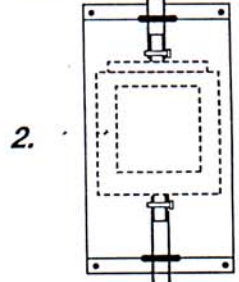

2.

- 1] Remove pump cover by undoing recessed fixing screws.
- 2] Pass Discharge and Suction Pipes through grommets in top cover.
- 3] Fix pipes to pump.
- 4] Fix clip around pipe on discharge outlet and tighten.
- 5] Re-fit top cover.

3

3.

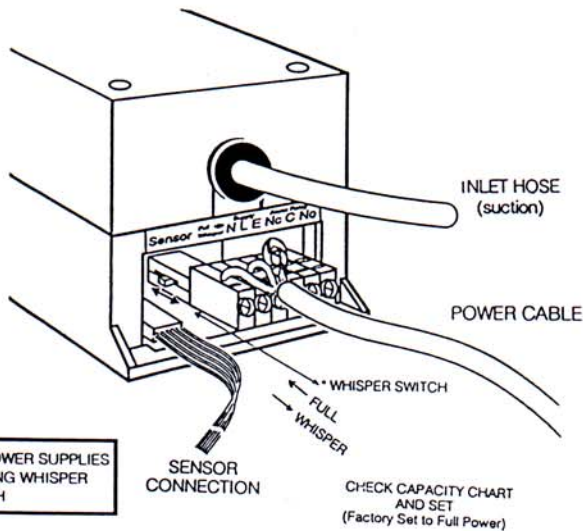

**DISCONNECT ALL POWER SUPPLIES BEFORE ADJUSTING WHISPER SWITCH**

**NOTE:** Pumping capacity and noise levels are reduced when set for "Whisper" operation. See Capacity Chart.

4.

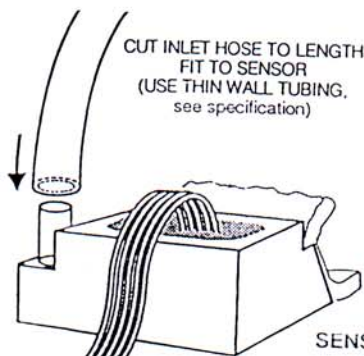

5.

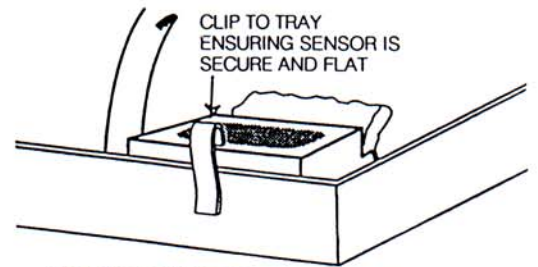

**FILTER ALIGNMENT**

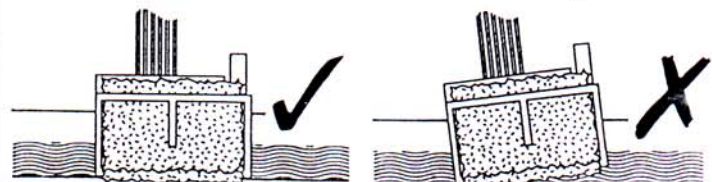
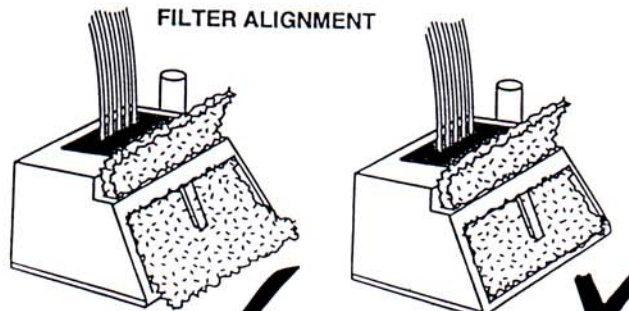

**SENSOR ORIENTATION**

4

**6. SETTING THE “WhisperSwitch”**

**Note:** Disconnect Power supplies before adjusting switch position.

The switch is located to the left of the mains terminal block connector, inside the terminal opening. It is a two-way slide switch, and when moved to the back of the mains terminal block the pump is in its **full power** position. To operate in the “**WhisperMode**” position this switch should be moved to the front, using the blade of a small screwdriver.

**Note:** pumping capacity, as well as noise level, is reduced when operating in the “**WhisperMode**”. The pump fitted to the **WaterWay MasterPump** is a powerful piston pump capable of pumping 9 metres higher than its outlet connection. In many cases this will not be required and “**WhisperMode**” can be used to dramatically reduce the pump noise level. The Pumping Capacity Charts should be consulted if there is any doubt about which switch position is suitable for a particular installation.

**7. CHECK LIST**

- 1) Check electrical connections (see wiring diagram).
- 2) Check 3A fuse fitted.
- 3) Check hose connection and tube free from kinks and blockages.

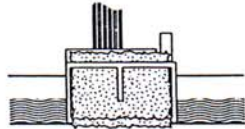

- 4) Check sensor is flat.
- 5) Check Whisper switch for full power or whisper requirements.

**8. TESTING**

**Note:** Observe Safety before commencing Tests.

- 1) Switch on power.
- 2) Add water to collection tray.
- 3) Make sure water is pumped away.
- 4) Allow water to prime complete tubing system and check Pumping Capacity and for leaks

**WIRING DIAGRAM**

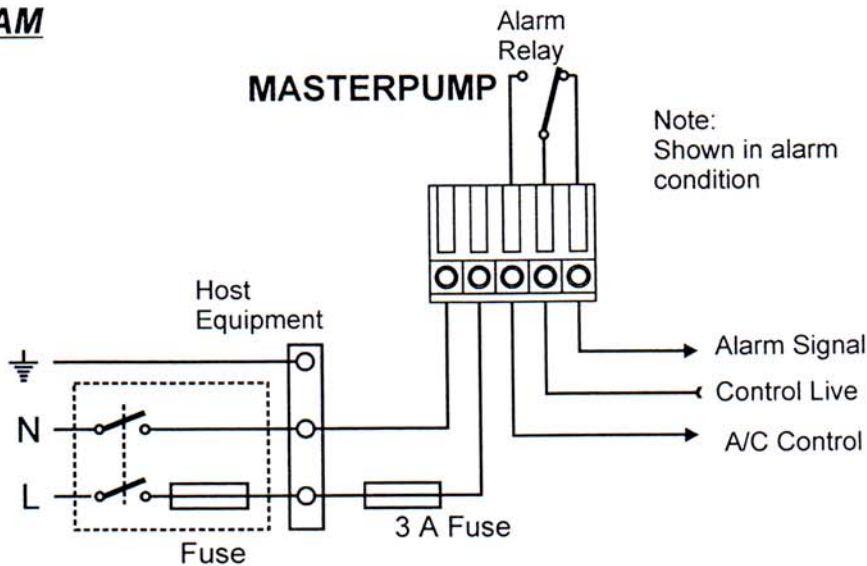

**3 Air Conditioners - 1 Alarm**

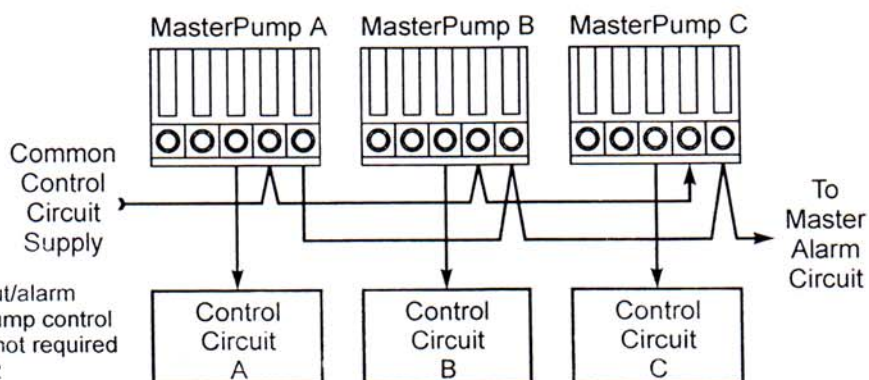

**Note:** High-water-level-cut-out/alarm circuit is independent from pump control circuit. If these features are not required wire only to terminals 1 and 2

## TROUBLESHOOTING

This guide is for use only by **Competent Service Engineers**. Always refer to Safety Section before commencement of maintenance.

PROBLEM	PROBABLE CAUSE	REMEDY
The pump does not work.	No power supply. Water not reaching sensor. Delivery pipe obstructed.	Check the electrical connections and the voltage of the power supply (max. 254V). Check gravity feed to sensor. Check filter is not blocked. Check sensor positioning. Check and eliminate the obstruction.
The pump runs continuously.	Inlet pipe disconnected or restricted. Sensor orientation.	Refit and secure. Check instructions and refit.
The pump does not drain the condensate	The sensor filter is clogged or the air hole is blocked. The delivery pipe is blocked.	Clear obstructions, clean or replace the filter. Check tube is not pinched. Check and eliminate the obstruction.
Pump cuts off intermittently.	Pump Thermal protection has operated. See probable cause for pump runs continuously.	Check installation of sensor. Check for blockage.
Pump noisy.	Pumping air. Pump vibrates on equipment housing. Pump mode incorrect setup for application.	Check sensor orientation. Check for contaminants in sensor compartment. Insulate pump and adjacent tube with foam rubber. Check sensor and hose connection. Select "Whisper" if appropriate.

If problems persist contact EDC Technical Helpline.

7

## SERVICE AND MAINTENANCE

### ***Maintenance of the Sensor Probe Head***

The only maintenance needed is to check that the filter is clean, and to remove any debris that has built up. While this is being done the probes themselves can be inspected for cleanliness by removing the clip-on base of the sensor moulding. The probes should not be allowed to become contaminated particularly with oil, since any coating may affect their conductivity, and their subsequent ability to operate correctly. If oil contamination is suspected, the whole sensor Probe Head can be cleaned in washing-up liquid and thoroughly rinsed. *The probe cover must be re-fitted before the Probe Head is replaced in the tray, by fitting the four studs on the cover into the holes in the sensor moulding and pressing the two parts together.*

### **AUXILIARY PARTS**

#### **FLOAT SWITCH**

**Note:** oils or fats are often present in the water from refrigeration applications (and in air conditioned food processing plants or kitchens). If this is the case use one of the **WaterWay Float Switch** Assemblies (Contact your Distributor) instead of the Standard Probe Head.

MSP 0040.1. - 2 Float switches and interface unit.  
MSP 0040.0. - 2 Float switches and Bracket.  
MSP 0042.0. - Sensor-Sump enclosure for Air Handler.

Contact EDC for more information.

### **GUARANTEE AND WARRANTY**

The product described in this manual is subject to continuous development and improvement and EDC International Limited reserves the right to alter the specifications or design without prior notice. Neither the whole nor any part of the information described in this manual, nor any part of the product therein described, may be adapted or reproduced in any form without the written approval of EDC International Limited.

EDC International Limited can accept no liability whatsoever for any loss or damage arising from the product being serviced, maintained or repaired by unauthorised personnel.

If, after Troubleshooting Section, there still appears to be a fault, contact the EDC Technical Helpline before returning goods.

Goods should be returned complete and with a description of fault and installation details to help establish cause of fault and warranty condition.

© EDC International Limited 1997.



***EDC International Ltd***

24 Horseshoe Park, Pangbourne, Berkshire,  
RG8 7JW, England.

Telephone: +44 (0) 118 984 2991

Telefax: +44 (0) 118 984 5300

**EDC Helpline: +44 (0) 118 984 5218**

